



### Specifications



**AHD-3**



#### Package Includes

- ✓ Stainless Steel Front Cover
- ✓ HEPA filter
- ✓ Voltage AC 110-120V Single-phase
- ✓ Input 1200-1450W
- ✓ All hardware necessary for satisfactory installation

#### 01 Featuring

- ✓ 0-15 seconds dry time, quick dry for your hands
- ✓ 80% less energy than conventional hand dryers
- ✓ HEPA Filtration System proven to remove 99.97% of potential bacteria
- ✓ 304 stainless steel one-piece molded cover, stable and durable
- ✓ Smart Heater adjusts based on environment temperature, LED indicator
- ✓ CE/UL approval electric parts and overtime protection, quality, and safe
- ✓ 45 seconds overtime protection and overheating protection
- ✓ 83 dB Noise
- ✓ **Available in Twenty + Matching Finishes**

### Specifications and Dimensions

MODEL	AHD-3
<b>Voltage:</b>	110 - 120 Volt
<b>Phase:</b>	Single-Phase
<b>Input:</b>	1200 - 1450W
<b>Heating Power:</b>	650 - 750W
<b>Sensor Type:</b>	Active Infrared
<b>Sensing Range:</b>	6" - 8"
<b>Motor:</b>	Brush Motor
<b>Exhaust Air Speed:</b>	70 M/s
<b>Protection Class:</b>	IPX1 Protection
<b>Finishes:</b>	Available in 20+ Finishes

All Dimensions in Inches

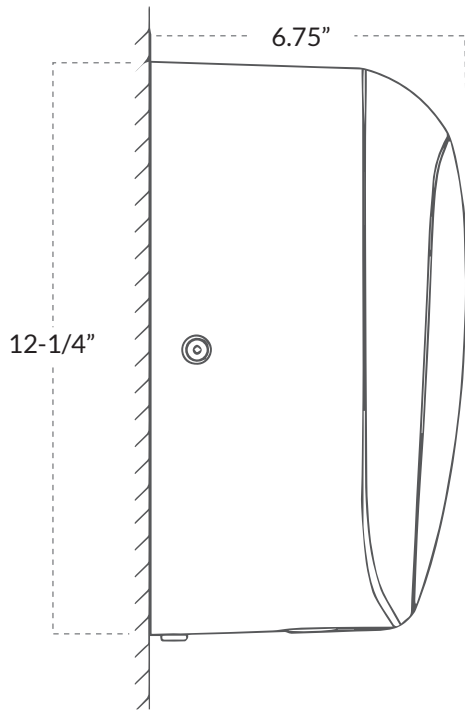
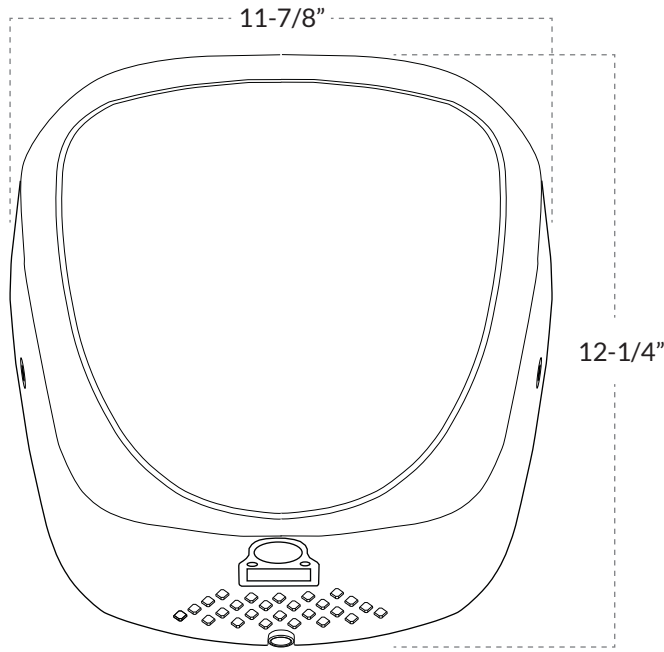

# MAC FAUCETS

When Style Matters



**AHD-3**

UL CE CB RoHS FC GS CCC



## Notes